

THE CLOSER AND EAR BRACKET MUST BE LEVEL(USE A SPIRIT LEVEL) TO ENSURE THEY RUN PARALLEL.

MAX OPENING 180°

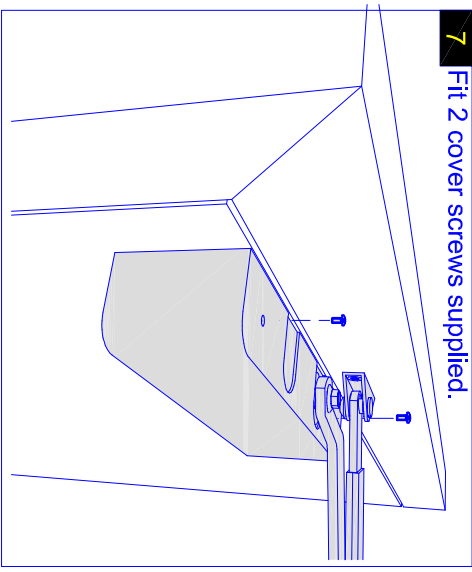
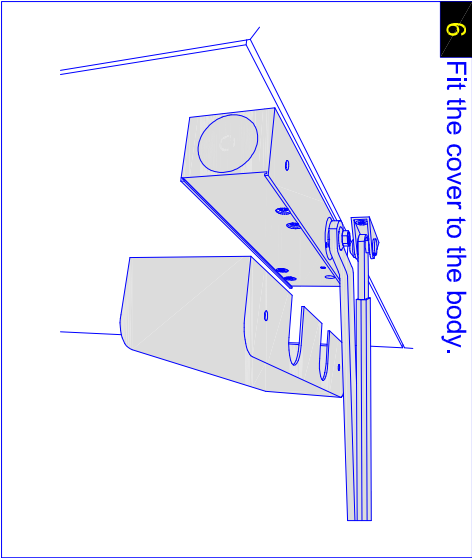
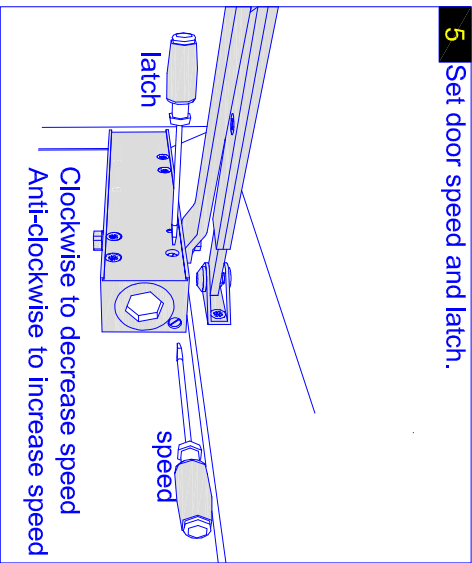
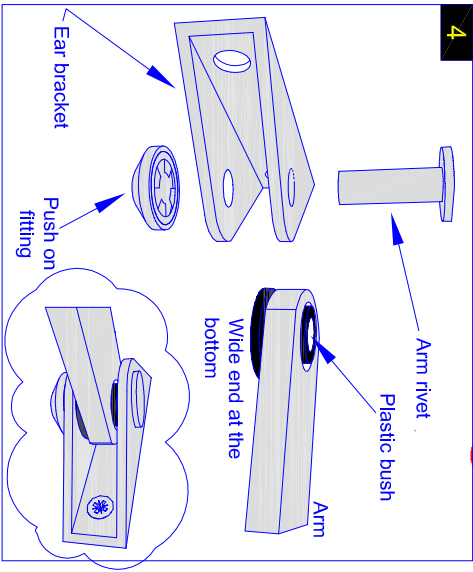
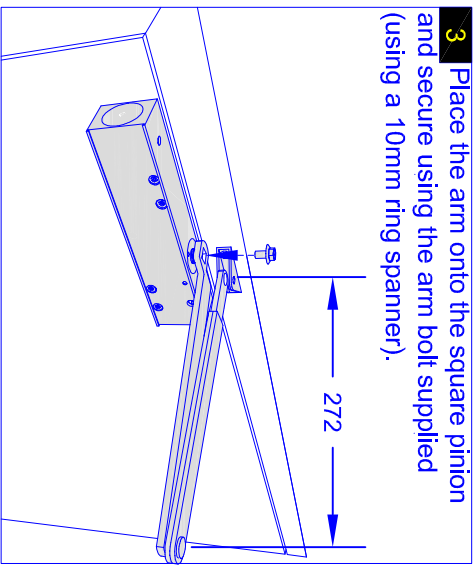
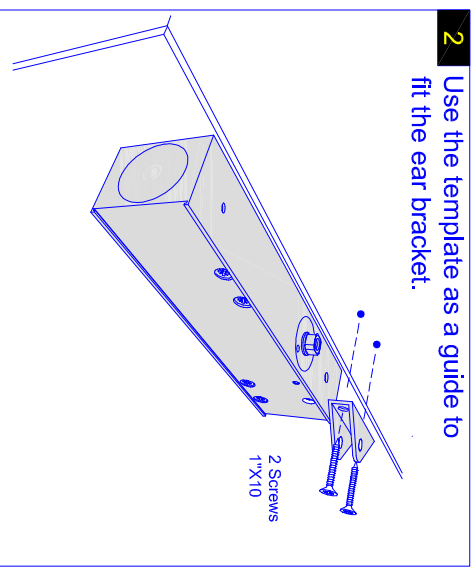
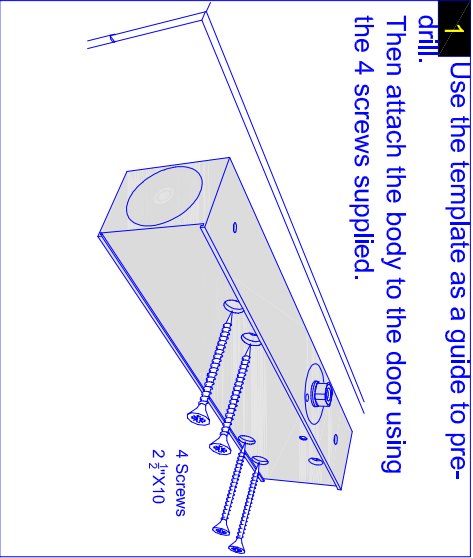
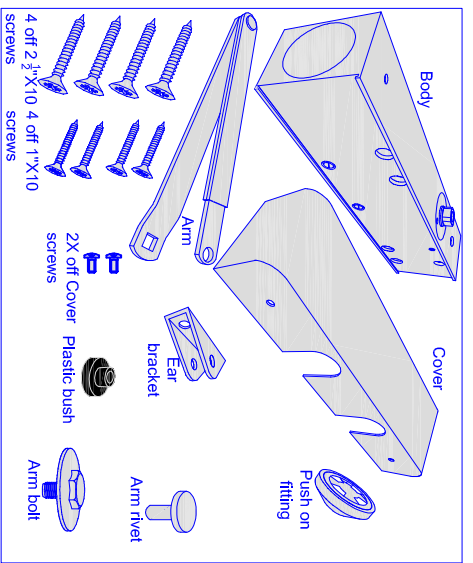

MAINTENANCE

Periodically apply light oil to the arm knuckle joint and check all screws and the pinion bolt are tight
 D.O.P download available at www.arrow-architectural.com

