



Transom concealed
door closer

DORMA RTS 85

Disappears into the frame

Ideal for shopfitting. For both double and single action doors. Elegant, versatile, practical and quality assured. The DORMA RTS 85 offers a solution for installations where door control must be provided without disturbing the aesthetic appearance of the door. The majority of preparation can be accomplished by the fabricator prior to installation,

leaving minimal on-site work. A complete line of accessories is available to accommodate virtually any door and frame configuration.



Plus points

For the trade

- Just **one** body for all types of fixing.
- Low inventory costs and minimal stocking requirement thanks to unit packs for closer body and accessories.

For the fabricator

- Can be used for double action doors, or left and right hand single action doors.
- Installation and setting adjustment possible before fixing the doorset on site.
- No floor preparation necessary.
- Positive "zero" position for double action doors – easy to adjust.
- Comprehensive range of accessories.

For the architect/specifier

- Aesthetically impressive solution – especially with toughened glass doors.
- Ideal for shopfitting applications.

For the user

- No cluttering of door or floor appearance.
- Backcheck to prevent door contact with the frame.
- Smooth closing with adjustable closing speed.

Technical Data		RTS 85		
		EN 3	EN 4	EN 5
Closing force				
Internal	up to 1950 mm	●	–	–
and external	1100 mm	–	●	–
doors*	1250 mm	–	–	●
Same model for double action doors, RH (ISO 5) and LH (ISO 6)		●	●	●
Closing speed variable by valve adjustment		●	●	●
Final closing speed variable by valve adjustment		●	●	●
Backcheck, progressive, mechanical		●	●	●
Backstop, mechanical		●	●	●
Hold-open	105°	○	○	○
	190°	○	○	○
Extended spindle	5 mm	○	○	○
	10 mm	○	○	○
Reduced pivot point for tempered glass doors	(65 mm)	○	○	○
Weight in kg		4.7	4.8	4.9
Dimensions in mm	Length	323	323	323
	Width	90	90	90
	Height	38	38	38
Door closer tested to EN 1154		●	●	●

● Yes – No ○ Option

* Max Door weight for floor pivot 8550–8557 90 kgs.
8560 G 200 kgs.

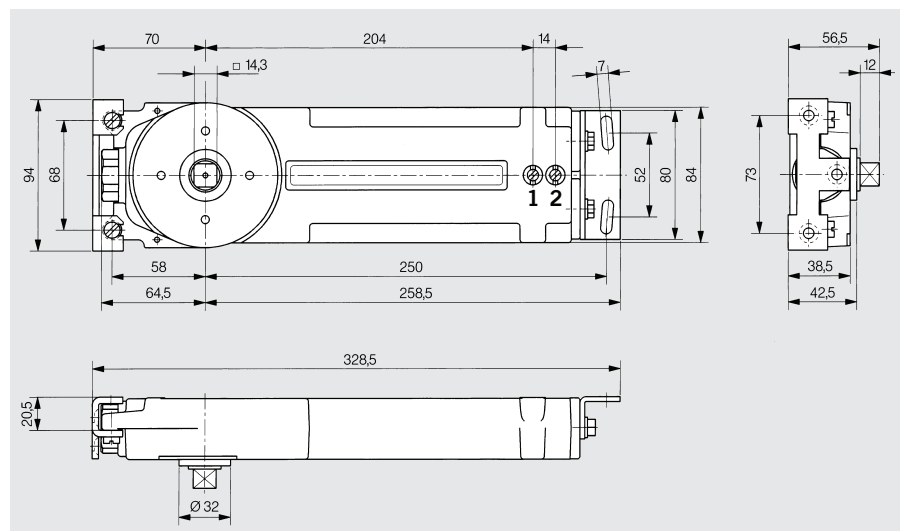
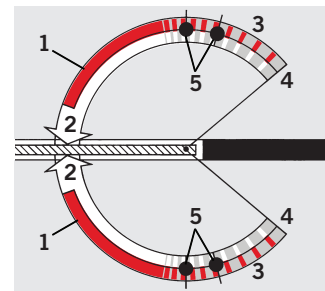

Standard and optional functions

- 1 Fully controlled closing with adjustable speed
- 2 Adjustable final closing
- 3 Progressive mechanical backcheck
- 4 Mechanical backstop**
- 5 Hold-open points – depending on model (optional) 105° or 90°

** Door opening angle max. 130° on both sides; in the case of heavy doors which can be opened further, door stops must be used. In the case of single action doors, the opening angle may be reduced depending on the door design.

Accessories for double action and centre pivoted single action doors (70 mm pivot point)
Side-load installation

Side-load installation is achieved by offering the door in the closed position, onto the floor pivot. The closer arm, fitted in the upper door rail, is connected to the spindle and secured with a clamping piece.

1 Closer arm with arm channel

Art.-No. 8530
for top rails with min. 15 mm channel depth and 38 mm width

2 Closer arm with angle bracket

Art.-No. 8531
for top rails with min. 12 mm channel depth and 38 mm width
(not suitable for doors with mitred-joints).

3 Floor pivot set

Art.-No. 8550/1
for bottom rails with channel depth of 18–50 mm. Floor portion of pivot is fitted directly to floor and adjustable in height.

4 Threshold pivot set

Art.-No. 8554/6
for bottom rails with channel depth of up to 50 mm. Floor clearance: 5 mm. Floor portion is fitted directly to threshold and adjustable in height.

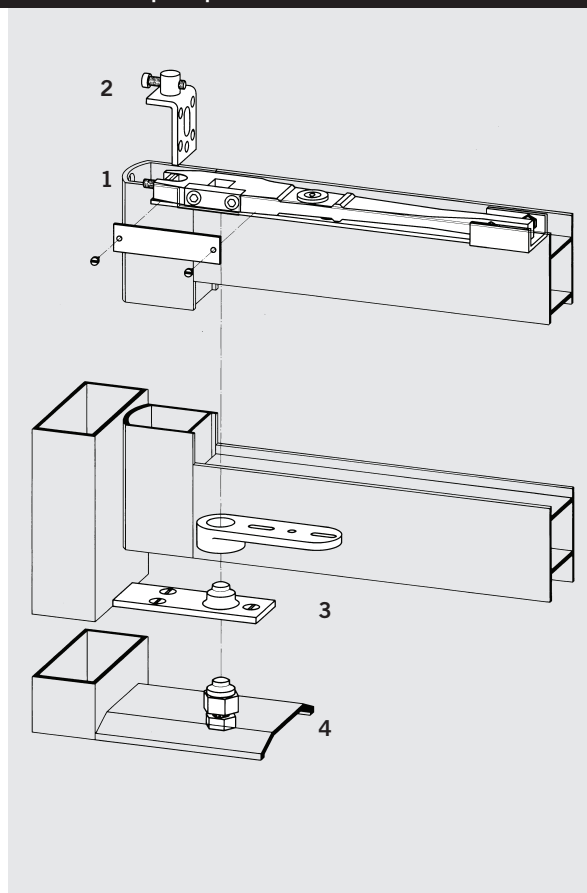
End-load installation

End-load installation is achieved by offering the door, in the open position, onto the floor pivot and spindle simultaneously. The floor pivot locks automatically, connection to spindle is secured with a clamping piece.

1 Closer arm with arm channel

Art.-No. 8534
for top rails with min. 21 mm channel depth and 35 mm width.

2 Closer arm with angle bracket

Art.-No. 8535
for top rails with min. 18 mm channel depth and 35 mm width
(not suitable for doors with mitred-joints).

3 Floor pivot set

Art.-No. 8552/3
for bottom rails with channel depth of up to 50 mm. Floor portion of pivot is fitted directly to floor and is adjustable in height.

4 Threshold pivot set

Art.-No. 8555/7
for bottom rails with channel depth of up to 50 mm. Floor clearance: 5 mm. Floor portion is fitted directly to threshold and is height adjustable.

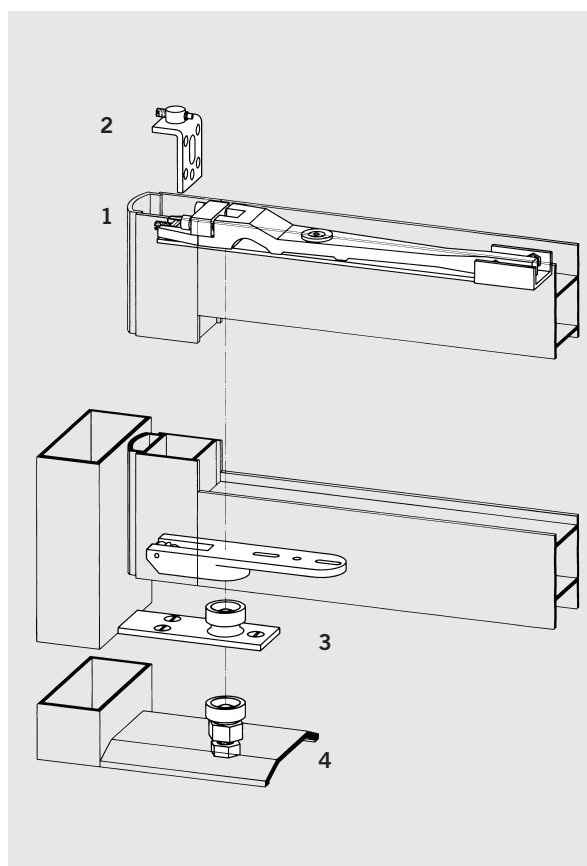

Accessories for butt hung or offset pivoted single action doors

Single action doors hung on butt hinges or offset pivots can be connected to the closer with slide arm and channel assemblies. Please note that this application may reduce the maximum opening angle available on the door. Similarly, if a hold-open model has been selected, the hold-open point will be altered: eg instead of 105°, the position

will lie between 90° and 100°, depending on door thickness.

Note:
Maximum door opening with slide arm and channel assemblies –105°. Consult our Technical Service Department giving specific details for slide arm and channel assemblies. Drawings of door and frame

details must be submitted together with the pivot centre of the hinge.

1 Slide arm and channel
Art.-No. 8510

2 Weld-on extension
Art.-No. 8521
For steel doors, 40 mm long (can be shortened), 38 mm dia.

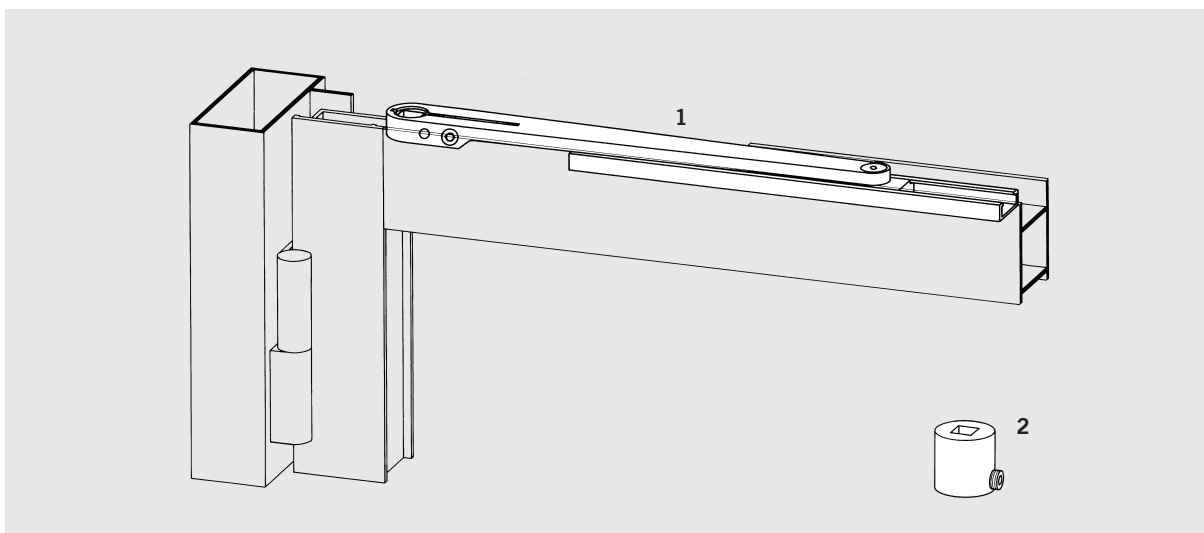

Accessories for tempered glass doors (65 mm pivot point)

For tempered glass doors, the RTS 85 is used with a special fixing bracket, Art.-No. 8520 G, giving a 65 mm pivot point. The standard patch fittings can thus be used with appropriate inserts. (Patch fittings with insert available from DORMA Glass range of products).

1 Fixing bracket
Art.-No. 8520 G
For fixing the DORMA RTS in the transom.

2 Floor pivot bearing with flat-tapered spindle
Art.-No. 8560 G
With sealed roller bearing assembly, rust-protected, for max. door weights of 110 kg (if used without the transom concealed door closer, then 200 kg).

Special pivots also available with extended spindles of 5, 10 and 15 mm, and also for special environments (e.g. wet rooms) in stainless steel; Art.-No. 8560 GE (only available with standard spindle).

The floor pivot bearing combined with appropriate bottom straps from the accessories range for DORMA BTS floor springs is also suitable for aluminium, steel and timber doors.

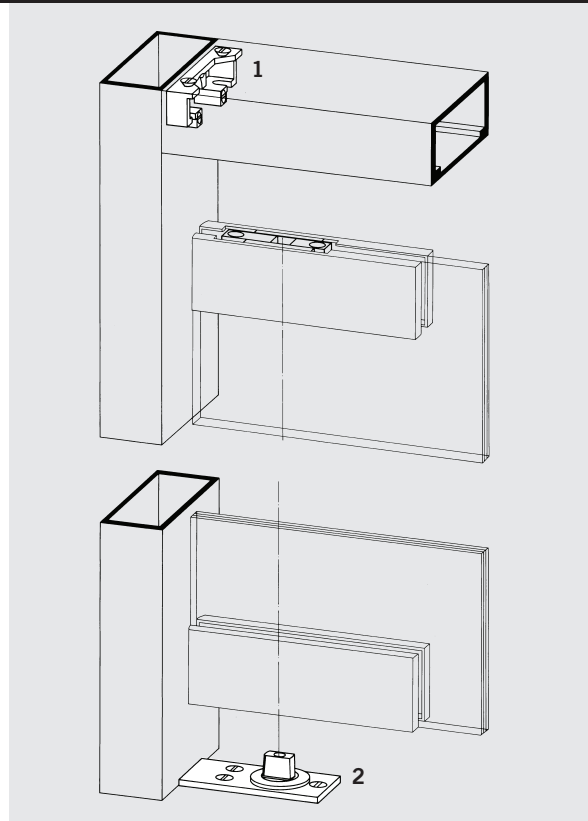

Typical applications

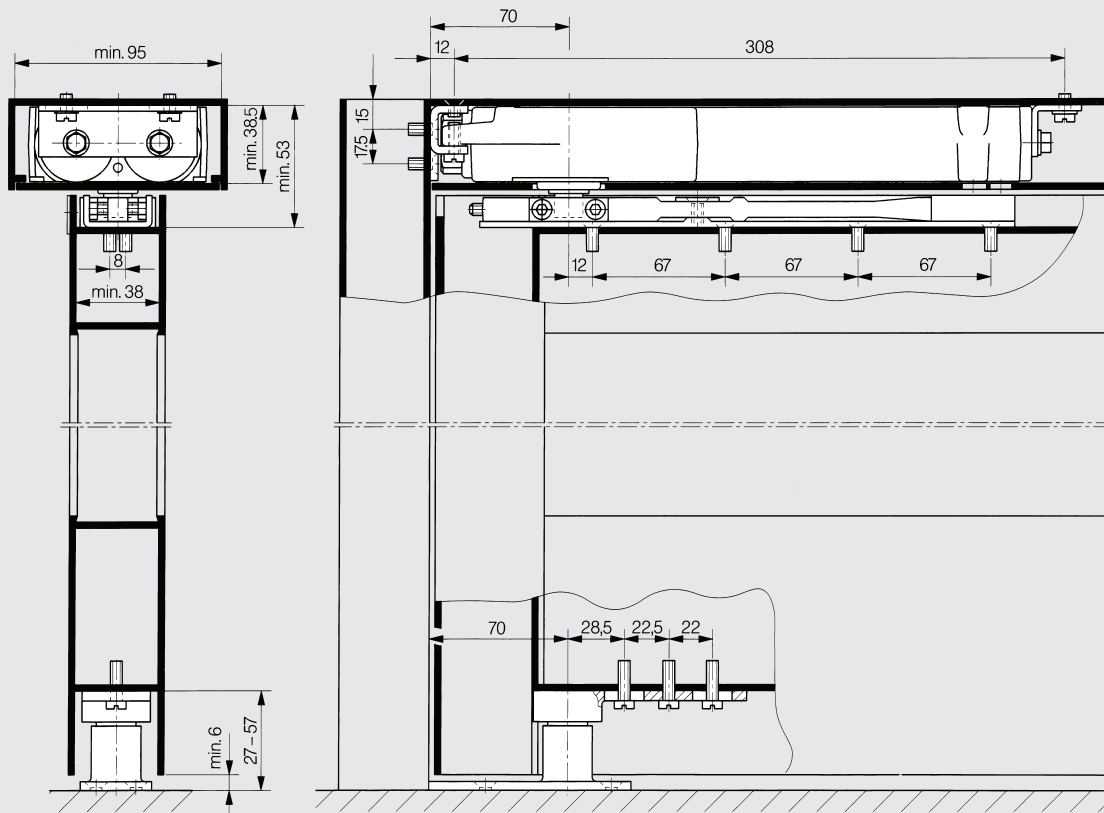

Double action aluminium door

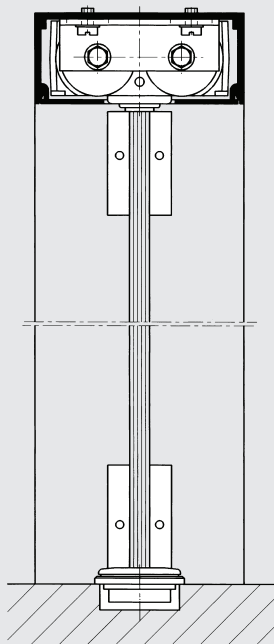

Double action tempered glass door with aluminium frame

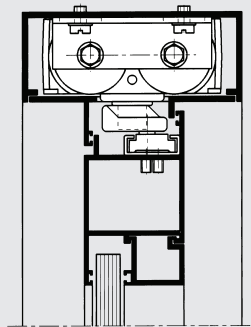

Single action double rebated aluminium door

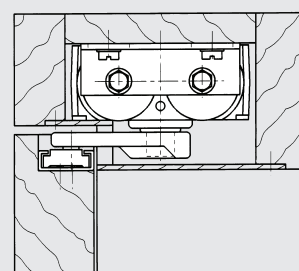

Single action timber door

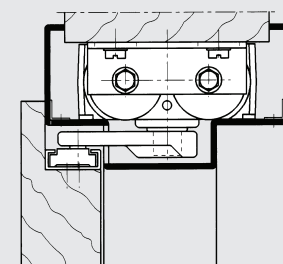

Single action timber door in a steel frame

Detailed installation drawings on a scale of 1:1 will be provided on request.

DORMA RTS 85 for double and single action doors

Door closer RTS 85	Standard model	Standard model with hold-open at 105°	Standard model with hold-open at 90°	with spindle insert 5 mm extended	with spindle insert 5 mm extended and hold-open at 105°	with spindle insert 5 mm extended and hold-open at 90°	with spindle insert 10 mm extended	with spindle insert 10 mm extended and hold-open at 105°	with spindle insert 10 mm extended and hold-open at 90°
EN 3	85311101	85313101	85312101	85311102	–	–	85311103	–	85312103
EN 4	85321101	85323101	85322101	85321102	85323102	85322102	85321103	–	85322103
EN 5	85331101	85333101	85332101	85331102	–	–	85331103	–	85332103

Accessories	closer arm with channel	closer arm with bracket	Floor pivot set, height 27 mm	Floor pivot set, height 57 mm	Threshold pivot set 1"	Threshold pivot set 1 9/16"	–	–	Closer arm with channel for single action doors	weld-on extensions
Side-load installation	85210005	85210007	65310300	65410300	65510400	65510500	–	–	85210001	85110001
End-load installation	85210009	85210011	65320300	65420300	65520400	–	–	–	–	–

DORMA RTS 85 for tempered glass doors

Door closer RTS 85 G	Standard model	Standard model with hold-open at 105°	Standard model with hold-open 90°	with spindle insert 5 mm extended	with spindle insert 5 mm extended and hold-open at 105°	with spindle insert 5 mm extended and hold-open at 90°	with spindle insert 10 mm extended	with spindle insert 10 mm extended and hold-open at 105°	with spindle insert 10 mm extended and hold-open at 90°
EN 3	85311301	85313301	85312301	85311302	–	–	85311303	–	85312303
EN 4	85321301	85323301	85322301	85321302	85323302	85322302	85321303	–	85322303
EN 5	85331301	85333301	85332301	85331302	–	–	85331303	–	85332303

Accessories	Floor pivot set	Floor pivot set 5 mm extended	Floor pivot set 10 mm extended	Floor pivot set 15 mm extended	Floor pivot set stainless steel
to RTS 85 G	65540000	85210025	85210026	85210027	85540059

Specification text

Transom concealed door closer with built-in cushion backcheck, adjustable closing speed and sweep range.

Size

- EN 3
 EN 4
 EN 5

Model

- For both single and double action doors (pivot point 70 mm)
 For tempered glass doors (pivot point 65 mm)
 Non hold-open
 Hold-open at 105°
 Hold-open at 90°
 With spindle insert 5 mm extended
 With spindle insert 10 mm extended
 Closer arm
 Art.-No. _____
 Floor pivot set
 Art.-No. _____

Make: DORMA RTS 85

DORMA UK Limited
 Wilbury Way
 Hitchin
 Herts SG4 0AB
 Tel. 01462 477600
 Fax 01462 477601
 E-mail:
 hardware@dorma-uk.co.uk

www.dorma-uk.co.uk

DORMA Ireland Limited
 19, Sandyford Office Park
 Foxrock
 Dublin 18
 Tel. 01 295 82 80-82
 Fax 01 295 85 84
 E-mail: dormadublin@dorma.ie

www.dorma.ie